

CONFIDENTIAL

THIS DOCUMENT AND INFORMATION CONTAINED HEREIN IS PROPRIETARY AND CONFIDENTIAL TO PRECOR STRENGTH INCORPORATED. RECIPIENTS OF THIS DOCUMENT AGREE THAT THIS DOCUMENT AND INFORMATION WILL NOT BE USED FOR ANY PURPOSE, REPRODUCED OR COPIED, OR DISCLOSED TO ANY THIRD PARTY, EITHER IN WHOLE OR IN PART WITHOUT PRIOR EXPRESS WRITTEN PERMISSION OF PRECOR STRENGTH, INCORPORATED.

PRECOR USA
PRECOR STRENGTH, INC.

28936 AVE WILLIAMS
VALENCIA, CA 91355
TELEPHONE: 661-362-0300

SIGN IN BLUE OR BLACK INK ONLY		UNLESS OTHERWISE SPECIFIED: DIMENSIONS ARE IN INCHES	
DRWN BY	01.02.07	MGP	TOLERANCES ARE:
DWG CHK			LIN .X=±0.1 .XXX=±0.010
ENG	01.02.07	RSG	LIN .XX=±0.02 .XXXX=±0.0001
MFG ENG			ANGULAR: ±1.0°
CS			ALL DIMS AFTER PLATING
QA			BREAK ALL SHARP EDGES
ID			REMOVE ALL BURRS
REG			ALL ANGLES & BENDS 90°
			DWG PER ASME Y14.5M-1994
			DO NOT SCALE DRAWING
			ALL MACHINED SURFACES

PRODUCT: **STRENGTH**

ASSEMBLY CONNECTION, 10.5, W/ 1 PULLEY HSG

DWG. NO.	SUBREV
CW31868-402	A

SIZE	PAGE	OF
C	1	1

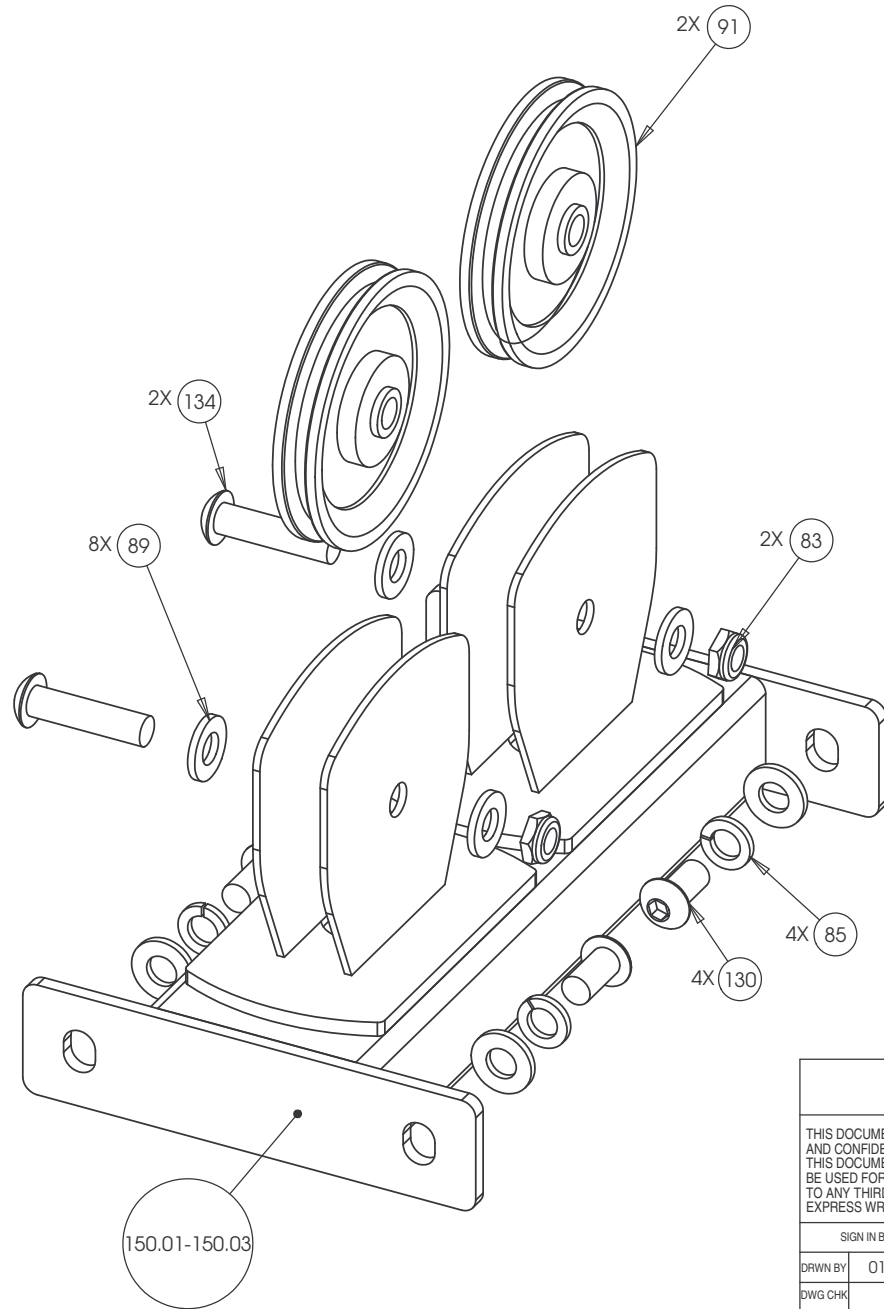

CONFIDENTIAL

THIS DOCUMENT AND INFORMATION CONTAINED HEREIN IS PROPRIETARY AND CONFIDENTIAL TO PRECOR STRENGTH INCORPORATED. RECIPIENTS OF THIS DOCUMENT AGREE THAT THIS DOCUMENT AND INFORMATION WILL NOT BE USED FOR ANY PURPOSE, REPRODUCED OR COPIED, OR DISCLOSED TO ANY THIRD PARTY, EITHER IN WHOLE OR IN PART WITHOUT PRIOR EXPRESS WRITTEN PERMISSION OF PRECOR STRENGTH, INCORPORATED.

PRECOR USA
PRECOR STRENGTH, INC.

28936 AVE WILLIAMS
VALENCIA, CA 91355
TELEPHONE: 661-362-0300

SIGN IN BLUE OR BLACK INK ONLY		UNLESS OTHERWISE SPECIFIED: DIMENSIONS ARE IN INCHES	
DRWN BY	01.02.07	MGP	TOLERANCES ARE:
DWG CHK			LIN .X=±0.1 .XXX=±0.010
ENG	01.02.07	RSG	LIN .XX=±0.02 .XXXX=±0.0001
MFG ENG			ANGULAR: ±1.0°
CS			ALL DIMS AFTER PLATING
QA			BREAK ALL SHARP EDGES
ID			REMOVE ALL BURRS
REG			ALL ANGLES & BENDS 90°
			DWG PER ASME Y14.5M-1994
			DO NOT SCALE DRAWING
			ALL MACHINED SURFACES
			SIZE PAGE OF
			C 1 1

PRODUCT:	STRENGTH
ASSEMBLY CONNECTION, 13.75, W/ 2 PULLEY HSG	
DWG. NO.	CW31876-402
SUBREV	A

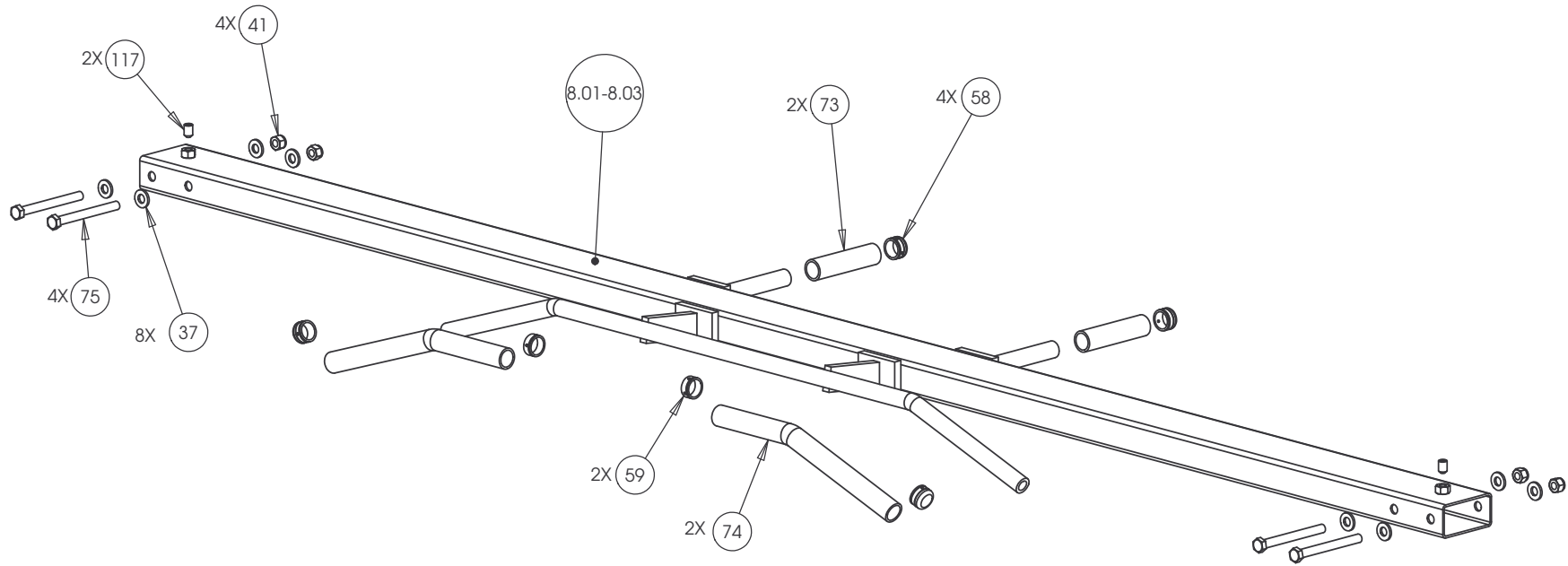

CONFIDENTIAL

THIS DOCUMENT AND INFORMATION CONTAINED HEREIN IS PROPRIETARY AND CONFIDENTIAL TO PRECOR STRENGTH INCORPORATED. RECIPIENTS OF THIS DOCUMENT AGREE THAT THIS DOCUMENT AND INFORMATION WILL NOT BE USED FOR ANY PURPOSE, REPRODUCED OR COPIED, OR DISCLOSED TO ANY THIRD PARTY, EITHER IN WHOLE OR IN PART WITHOUT PRIOR EXPRESS WRITTEN PERMISSION OF PRECOR STRENGTH, INCORPORATED.

PRECOR USA
PRECOR STRENGTH, INC.

28936 AVE WILLIAMS
VALENCIA, CA 91355
TELEPHONE: 661-362-0300

SIGN IN BLUE OR BLACK INK ONLY			UNLESS OTHERWISE SPECIFIED: DIMENSIONS ARE IN INCHES			PRODUCT:	
DRWN BY	01.02.07	MGP	TOLERANCES ARE:			STRENGTH	
DWG CHK			LIN	.X=±0.1	.XXX=±0.010	ASSEMBLY CONNECTION, 107 IN, CROSSBEAM W-HANDLES	
ENG	01.02.07	RSG	LIN	.XX=±0.02	.XXXX=±0.0001		
MFV ENG			ANGULAR: ±1.0°				
CS			ALL DIMS AFTER PLATING				
QA			BREAK ALL SHARP EDGES				
ID			REMOVE ALL BURRS				
REG			ALL ANGLES & BENDS 90°			DWG. NO.	
			DWG PER ASME Y14.5M-1994			CW31878-401	
			DO NOT SCALE DRAWING			SUBREV	
			ALL MACHINED SURFACES			A	
			SIZE	PAGE	OF		
			C	1	1		

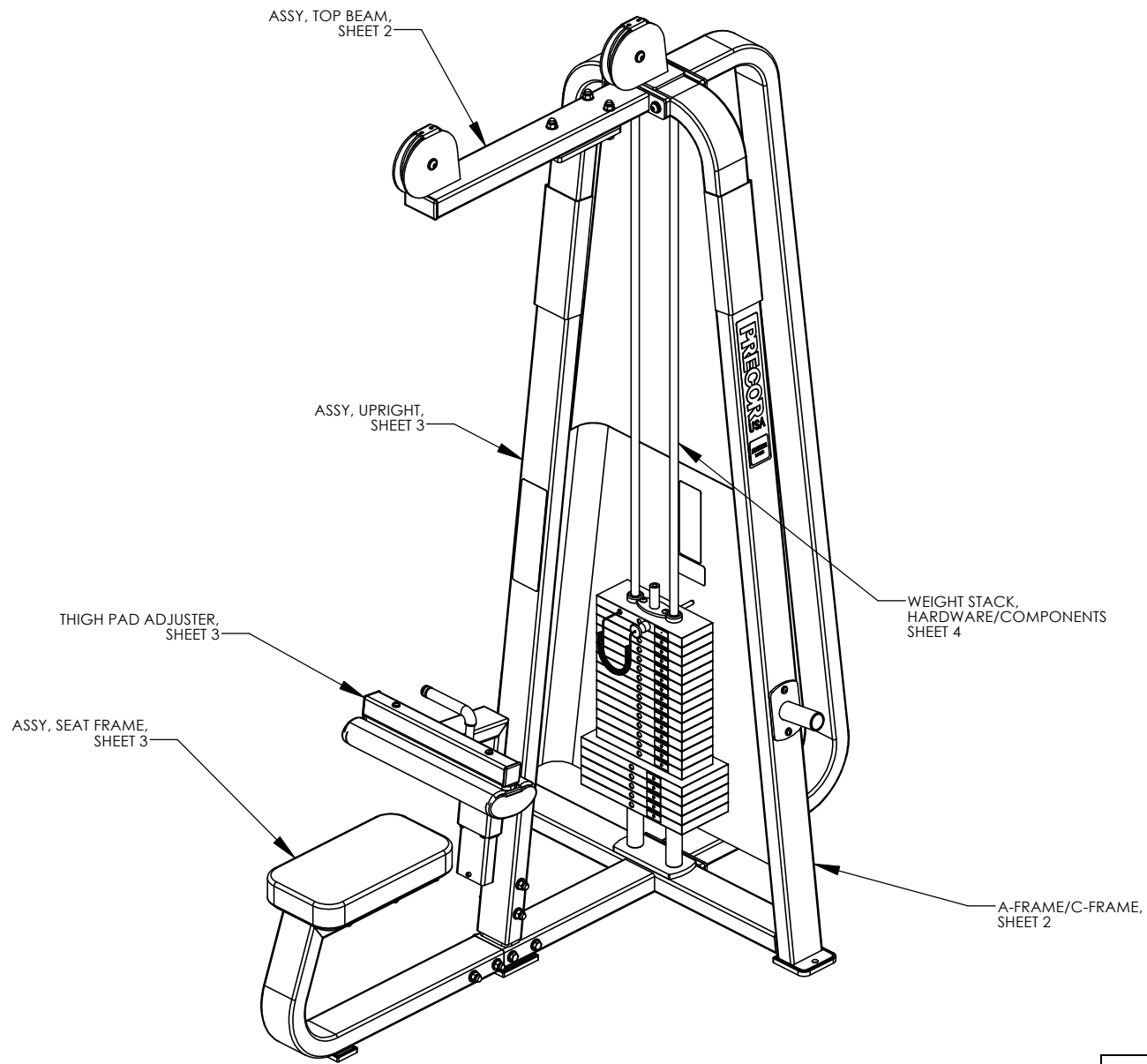

P/N: CW31932-402	SUBREV: C
DRAWN BY: JEC	DATE: 09.11.08
SHEET 1 OF 4	

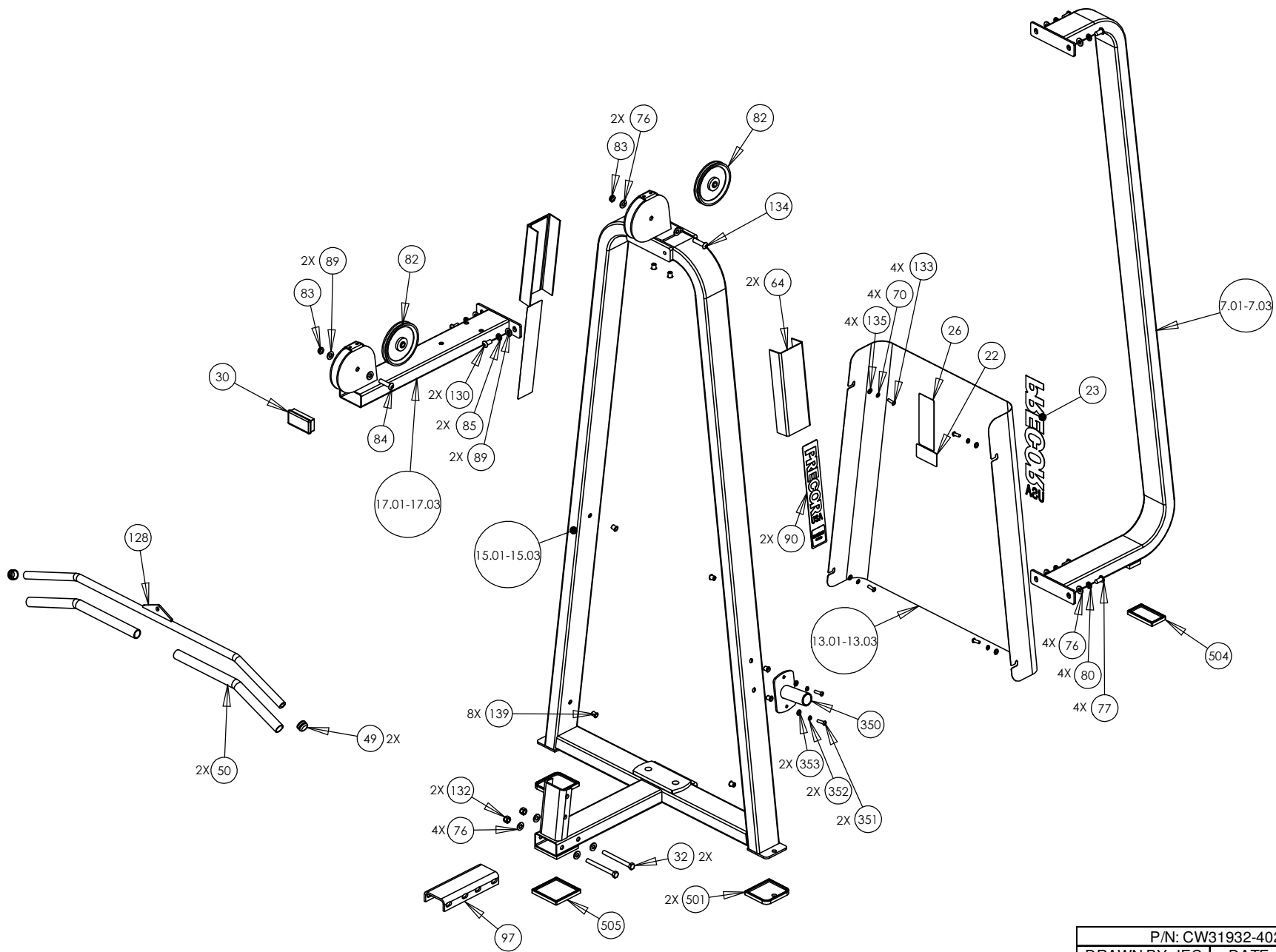

P/N: CW31932-402	SUBREV: C
DRAWN BY: JEC	DATE: 09.11.08
SHEET 2 OF 4	

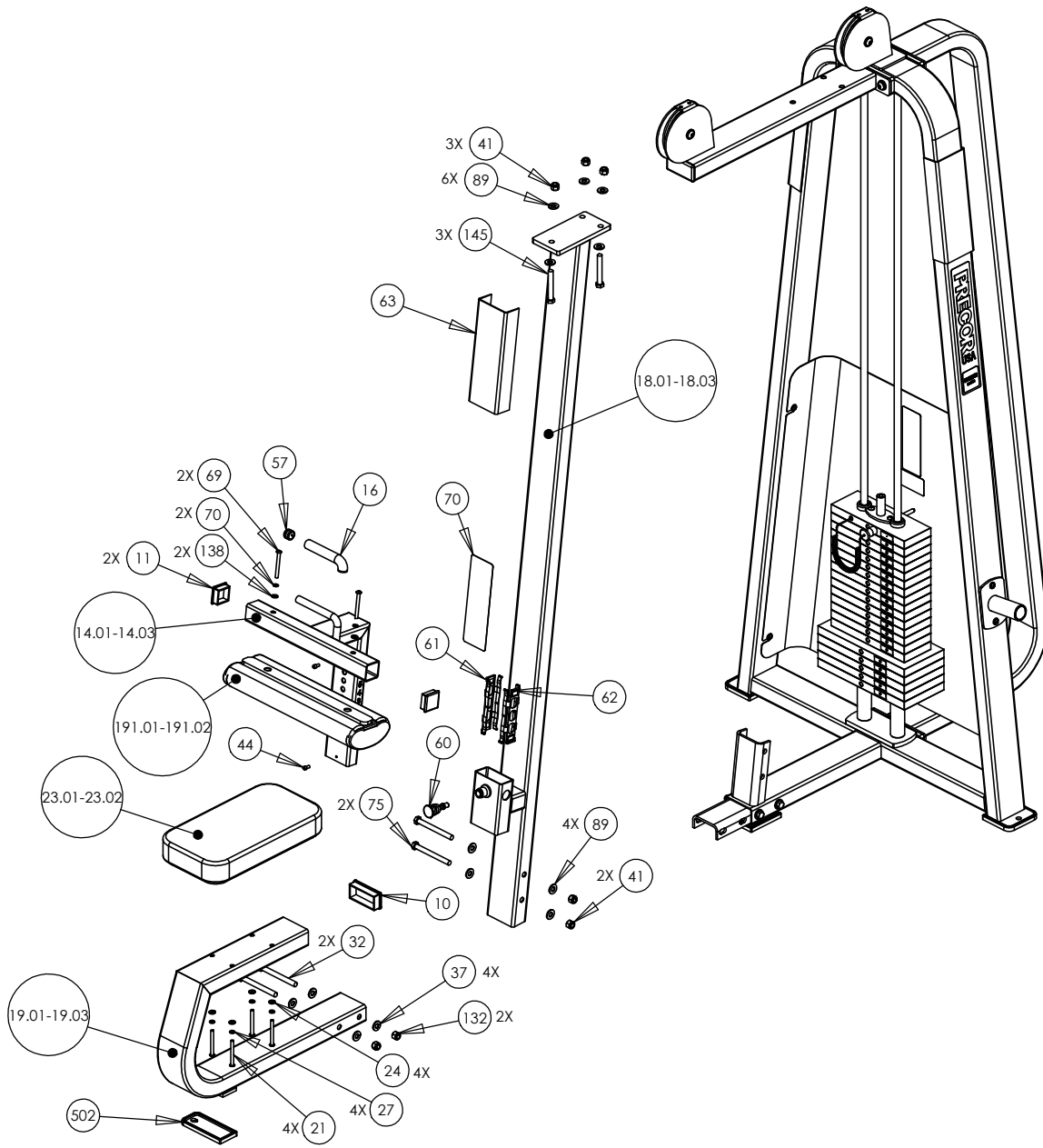

P/N: CW31932-402	SUBREV: C
DRAWN BY: JEC	DATE: 09.11.08
SHEET 3 OF 4	

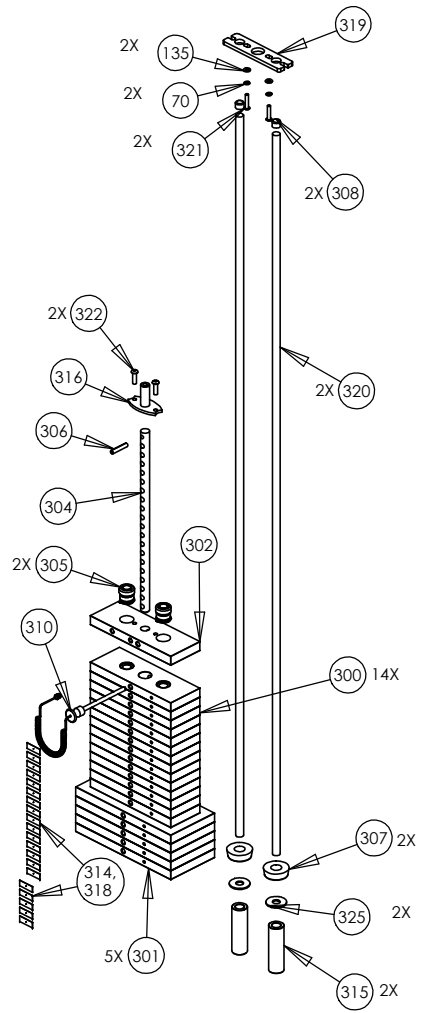
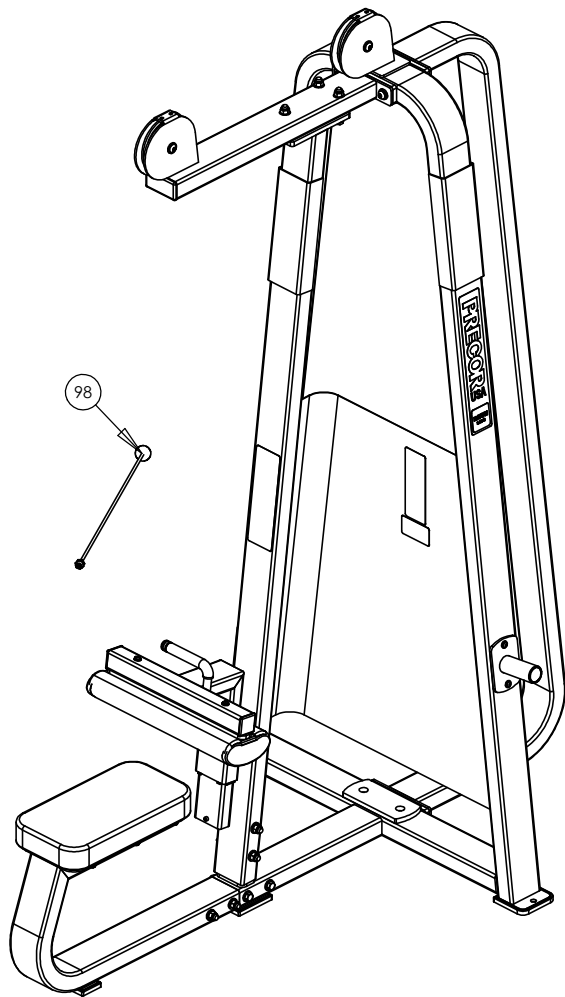

P/N: CW31932-402		SUBREV: C
DRAWN BY: JEC	DATE: 09.11.08	SHEET 4 OF 4

ASSY, FRAME, MAIN
PAGE 2

WEIGHT STACK,
HARDWARE/ COMPONENTS
PAGE 3

HARDWARE/COMPONENTS,
PAGE 2

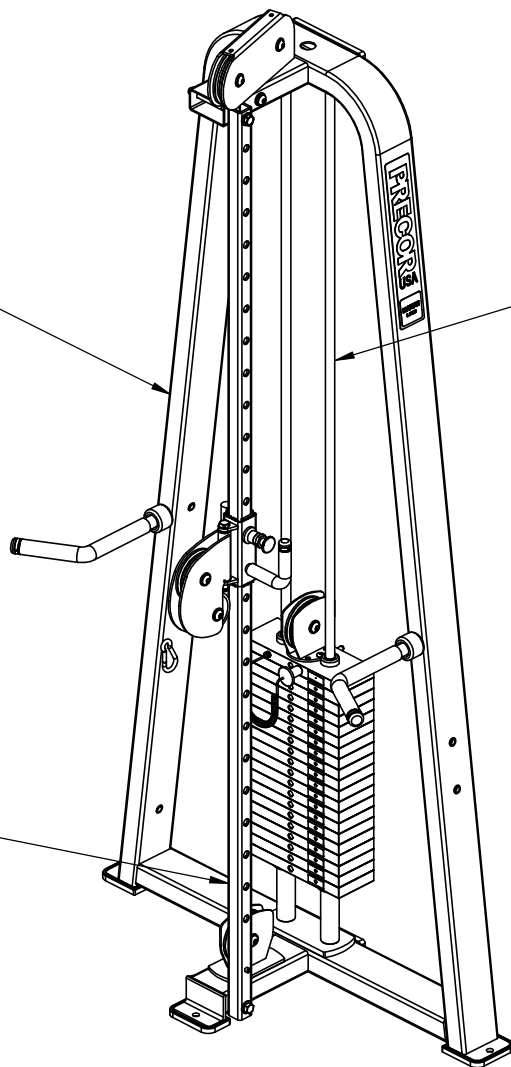

P/N: CW34920-401	SUBREV: A
DRAWN BY: VLE	DATE: 06.24.09
	SHEET 1 OF 3

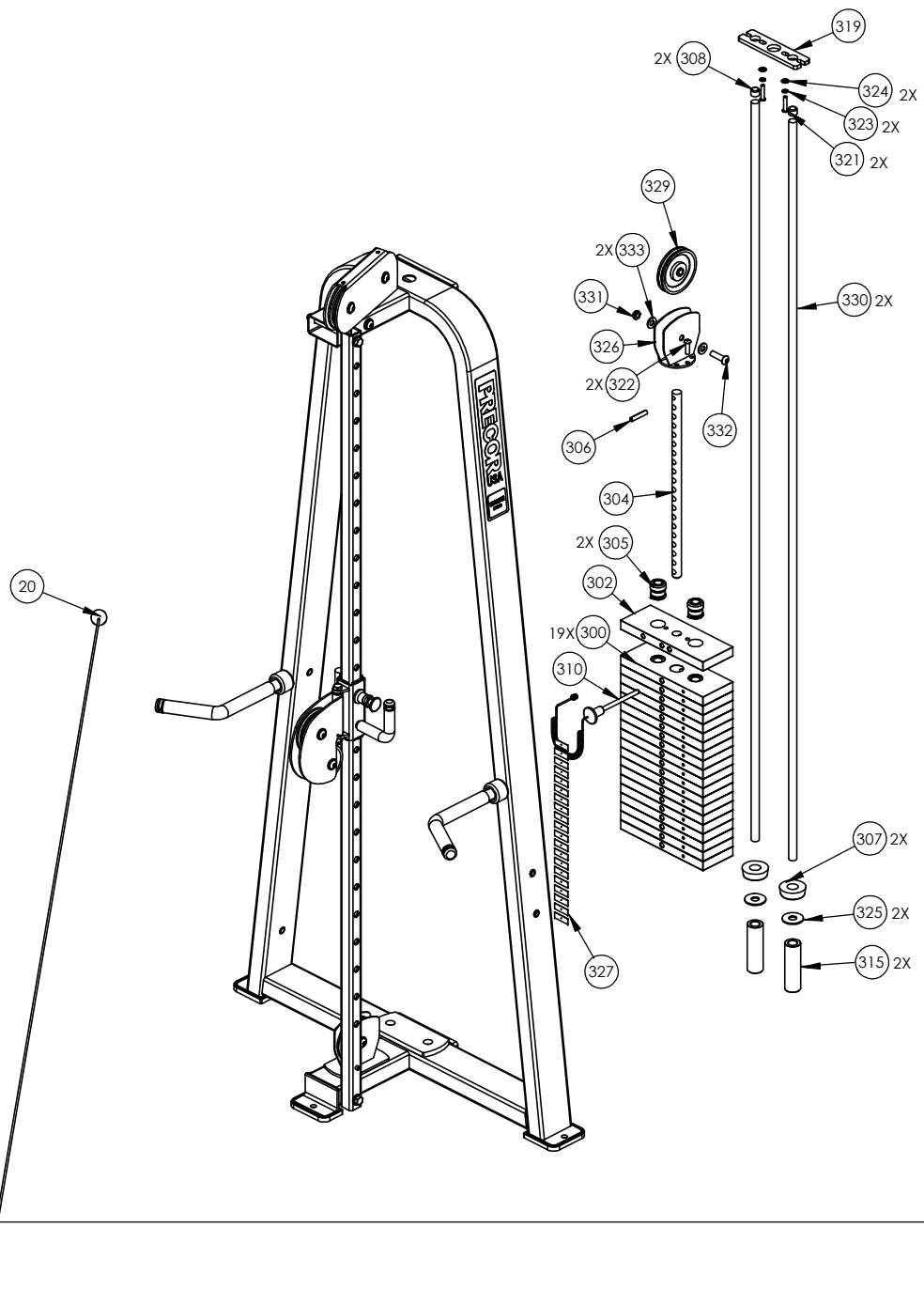

P/N: CW34920-401	SUBREV: A
DRAWN BY: VLE	DATE: 06.24.09
SHEET 3 OF 3	

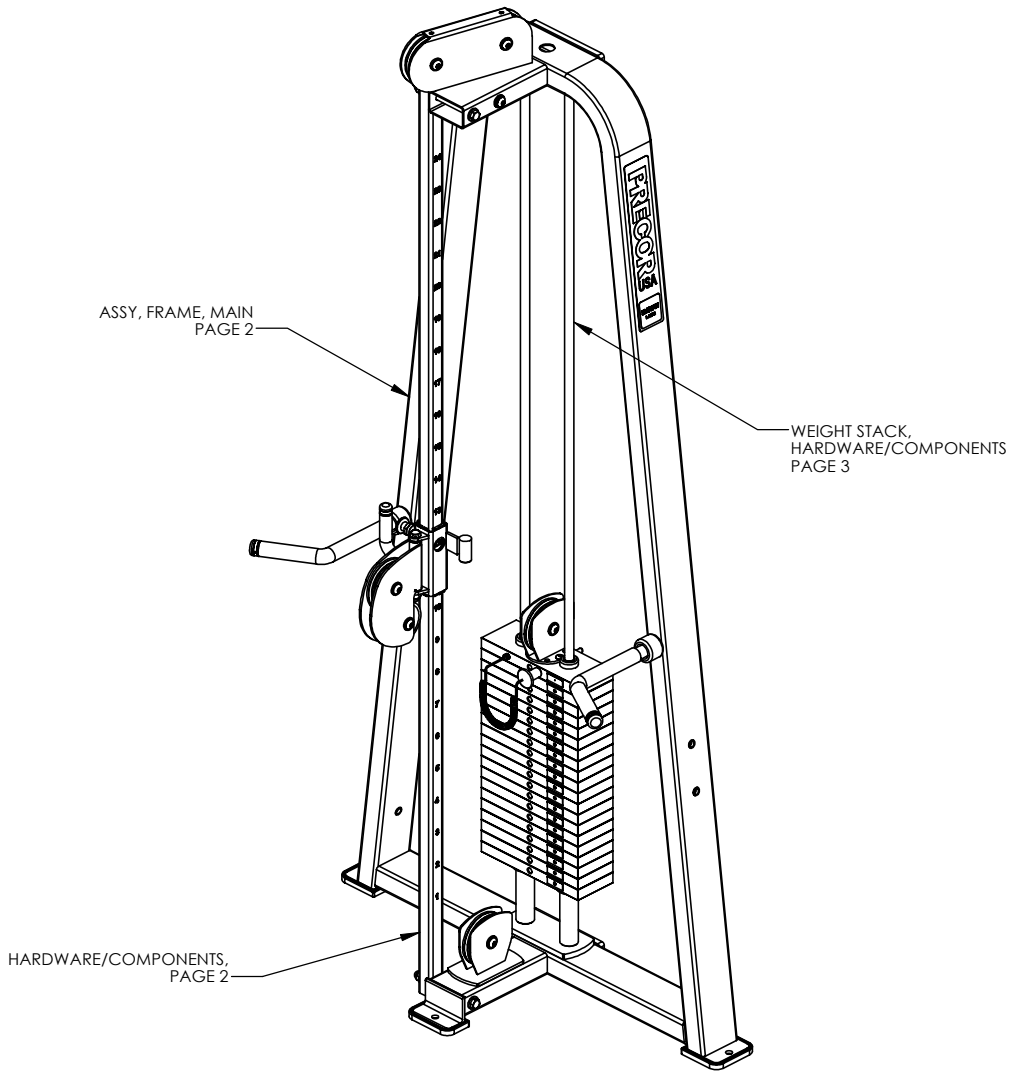

P/N: CW34921-401	SUBREV: A
DRAWN BY: VLE	DATE: 06.24.09
SHEET 1 OF 3	

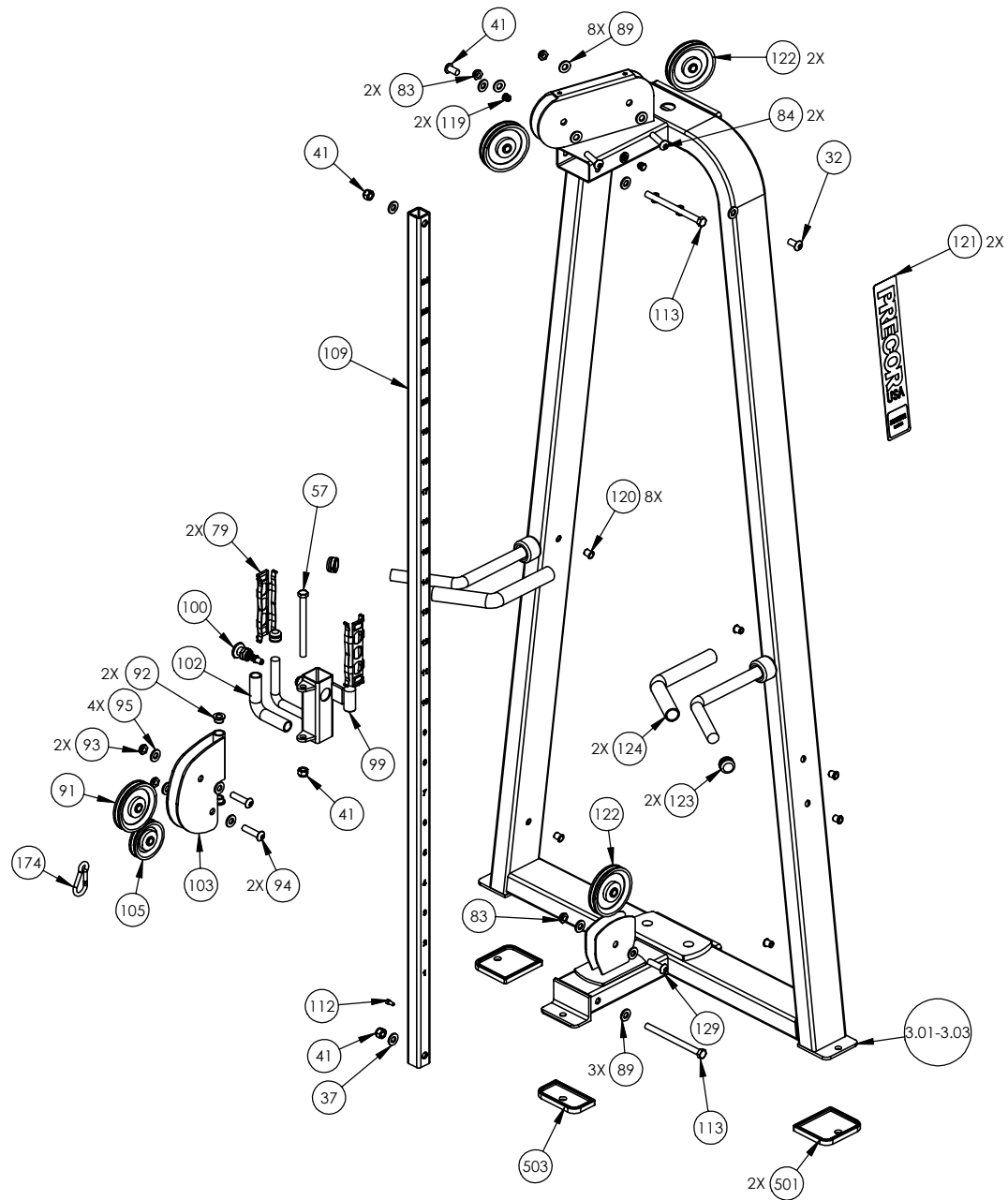

P/N: CW34921-401	SUBREV: A
DRAWN BY: VLE	DATE: 06.24.09
SHEET 2 OF 3	

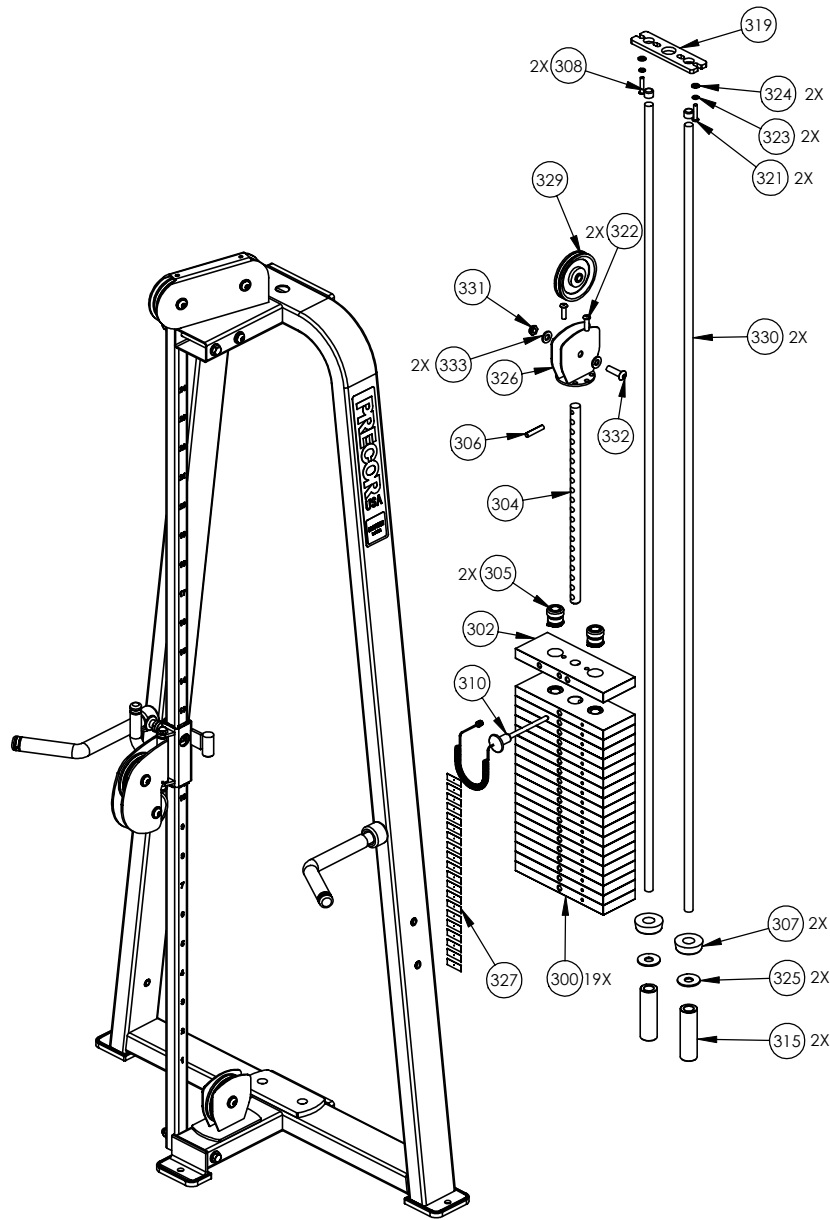

P/N: CW34921-401	SUBREV: A
DRAWN BY: VLE	DATE: 06.24.09
SHEET 3 OF 3	

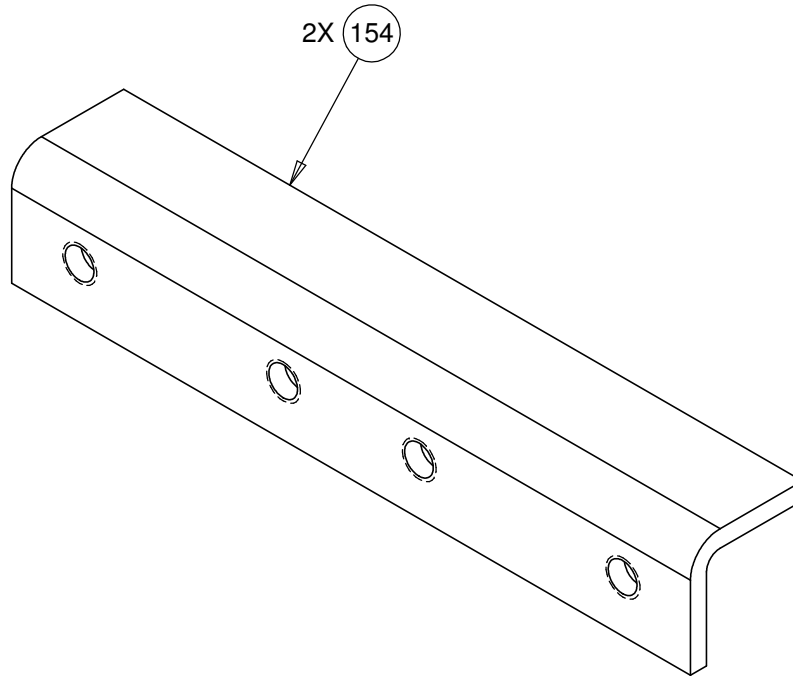

CONFIDENTIAL

THIS DOCUMENT AND INFORMATION CONTAINED HEREIN IS PROPRIETARY AND CONFIDENTIAL TO PRECOR STRENGTH INCORPORATED. RECIPIENTS OF THIS DOCUMENT AGREE THAT THIS DOCUMENT AND INFORMATION WILL NOT BE USED FOR ANY PURPOSE, REPRODUCED OR COPIED, OR DISCLOSED TO ANY THIRD PARTY, EITHER IN WHOLE OR IN PART WITHOUT PRIOR EXPRESS WRITTEN PERMISSION OF PRECOR STRENGTH INCORPORATED.

PRECOR USA
PRECOR STRENGTH, INC.

**28936 AVE WILLIAMS
VALENCIA, CA 91355
TELEPHONE: 661-362-0300**

SIGN IN BLUE OR BLACK INK ONLY			UNLESS OTHERWISE SPECIFIED: DIMENSIONS ARE IN INCHES TOLERANCES ARE:		
DRWN BY	08.27.09	VLE	LIN	.X=±0.1	.XXX=±0.010
DWG CHK			LIN	.XX=±0.02	.XXXX=±0.0001
ENG	08.27.09	VLE	ANGULAR: ±1.0°		
MFG ENG			ALL DIMS AFTER PLATING		
CS			BREAK ALL SHARP EDGES		
QA			REMOVE ALL BURRS		
ID			ALL ANGLES & BENDS 90°		
REG			DWG PER ASME Y14.5M-1994		
			DO NOT SCALE DRAWING		
			125° ALL MACHINED SURFACES		
			SIZE	PAGE	OF
			A	1	1

PRODUCT:
STRENGTH

STEEL, CHANNEL

DWG. NO. CW33293-402 SUBREV A

2182 Modular, Pulldown, Adj. Hi/Low (3X)

Part Number	Description	Bubble Number
PPP00000CW11311102	ENDCAP, REC TUBE, 2X4, BLK PLASTIC	10
PPP00000CW11311103	ENDCAP, REC TUBE, 2X2, BLK PLASTIC	11
PPP00000CW30641211	WELDMENT, THIGH PAD ADJUSTER, SKY WH	14.01
PPP00000CW30641301	WELDMENT, THIGH PAD ADJUSTER, CUSTOM	14.02
PPP00000CW30641321	WELDMENT, THIGH PAD ADJUSTER, TITANI	14.03
PPP00000CWGR4804500	GRIP, RUBBER, .75" OD HANDLE, 4.50"	16
PPP00000CW30636211	WELDMENT, TOP BEAM, 304, SKY WHITE	17.01
PPP00000CW30639212	WELDMENT, PULLDOWN UPRIGHT, SKY WHIT	18.01
PPP00000CW30640211	WELDMENT, PULLDOWN SEAT, SKY WHITE	19.01
PPP000CWCLRA319250	ASSY, CABLE, MARINE EYES, FTS, 407B	20
PPP000CWPD1105B101	PAD, 9X17, 4HOLES, W/BP, BLACK	23.01
PPP000CWPD1105B102	PAD, 9X17, 4HOLES, W/BP, RYL BL	23.02
PPP000CWPD1105B114	PAD, 9X17, 4HOLES, W/BP, CUSTOM	23.14
PPP000CWWBKN031007	WASHER, FLAT, TYPE A, SAE, 5/16 ID	24
PPP000CWWALYN050013	WASHER, SPLIT, 1/2 ID, BLK XYLAN	25
PPP000CWWALYN031008	WASHER, SPLIT, 5/16 ID, BL	27
PPP00000CW12589741	CARBINE, HOOK, MEDIUM, 5/16" DIA, 3	28
PPP00000CW11311102	ENDCAP, REC TUBE, 2X4, BLK PLASTIC	30
PPP000CWWBKN050010	WASHER, FLAT, TYPE A, SAE, 1/2 ID X	37
PPP000CWKDYN050059	LOCKNUT, NYLON INSERT, FULL, UNC, 1	41
PPP000CWCAYN025050	SCREW, SOCKET HEAD, BLK XYLAN	44
PPP000CWKAYN050031	LOCKNUT, NYLON INSERT, HALF, UNC, 1	48
PPP000CWWALYN050013	WASHER, SPLIT, 1/2 ID, BLK XYLAN	49
PPP00000CWGR4620000	GRIP, RUBBER, 1.00" OD HANDLE, 20.0	50
PPP00000CWAC220901	HANDLE END CAP W/SET SCREWS, DIA 3/	57
PPP00000CWAC218901	HANDLE END CAP W/SET SCREWS, DIA 1"	58
PPP00000CWAC219902	HNDL RETAINER RNG, W/SS, 1.040" I.D.	59
PPP00000CW30165752	ASSY, POP PIN, 0.450 DIA NOSE, BLU	60
PPP00000CWAC1236104	GUIDE INSERT, PLASTIC WITH HOLE, BL	61
PPP00000CW33508101	ASSY, CUT PIECE, ABS CHANNEL, 1/8 X	63
PPP00000CW33508101	ASSY, CUT PIECE, ABS CHANNEL, 1/8 X	64
PPP000CWWALYN031008	WASHER, SPLIT, 5/16 ID, BL	70
PPP000CWTAYN050200	SCREW, BUTTON HEAD, BLK XYLAN, 1/2	71
PPP000CWWBKN050010	WASHER, FLAT, TYPE A, SAE, 1/2 ID X	72
PPP00000CWGR4605000	GRIP, RUBBER, 1.00" OD HANDLE, 5.00	73
PPP000CWHCYN050500	SCREW, HEX HEAD, BLK XYLAN, 1/2-13	75
PPP000CWWBKN050010	WASHER, FLAT, TYPE A, SAE, 1/2 ID X	76
PPP000CWHCCN050600	SCREW, HEX HEAD, ZINC, 1/2-13 X 6	78
PPP00000CW33626901	GUIDE, THIN, TELESCOPING TUBE	79
PPP00000CWAC1010101	PULLEY, 6 DIA X 1/2 ID	82
PPP00000CWKAYN050031	LOCKNUT, NYLON INSERT, HALF, UNC, 1	83
PPP000CWTAYN050200	SCREW, BUTTON HEAD, BLK XYLAN, 1/2	84
PPP000CWWALYN050013	WASHER, SPLIT, 1/2 ID, BLK XYLAN	85
PPP000CWWALYN031008	WASHER, SPLIT, 5/16 ID, BL	87
PPP00000CWWBKN031007	WASHER, FLAT, TYPE A, SAE, 5/16 ID	88
PPP00000CWWBKN050010	WASHER, FLAT, TYPE A, SAE, 1/2 ID X	89
PPP00000CW31756101	LABEL, PRECOR USA ICARIAN LINE	90
PPP00000CWAC1009101	PULLEY, 4 1/2 DIA X 1/2 ID	91
PPP00000CW10433108	BUSHING, FLNGD, .75ODX.5IDX.5, IGUS R	92

PPP000CWKAYN050031	LOCKNUT, NYLON INSERT, HALF, UNC, 1	93
PPP000CWTAYN050200	SCREW, BUTTON HEAD, BLK XYLAN, 1/2	94
PPP000CWWBKN050010	WASHER, FLAT, TYPE A, SAE, 1/2 ID X	95
PPP00000CWAC218901	HANDLE END CAP W/SET SCREWS, DIA 1"	96
PPP00000CW33293733	STEEL, ANGLE, HR, [3.15 X .25 X 1.6	97
PPP000CWCLGY101125	ASSY, CABLE, MARINE EYES, 304SM	98
PPP00000CW30165752	ASSY, POP PIN, 0.450 DIA NOSE, BLU	100
PPP00000CWAC220901	HANDLE END CAP W/SET SCREWS, DIA 3/	101
PPP00000CWGR4806000	GRIP, RUBBER, .75" OD HANDLE, 6.00"	102
PPP00000CW30497721	WELDMENT, W/2 PULLEY WHEELS, WRKL B	103
PPP00000CWAC1008101	PULLEY, 3 1/2 DIA. X 1/2 ID	105
PPP00000CWPF4020713	TUBE,STEEL,HRPO, 1 1/2 X 1 1/2 X 3/	109
PPP00000CWCAYN025050	SCREW, SOCKET HEAD, BLK XYLAN	112
PPP00000CWHCCN050600	SCREW, HEX HEAD, ZINC, 1/2-13 X 6	113
PPP00000CW35150101	ASSY, D- HANDLE	114
PPP00000CWTAYN031100	SCREW, BUTTON HEAD, BLK XYLAN, 5/16	114
PPP00000CWEANN050075	SCREW, SET, SCKT, CUP POINT, 1/2-13	117
PPP00000CW11311102	ENDCAP, REC TUBE, 2X4, BLK PLASTIC	118
PPP00000CW11382105	CAP, TUBE, PLASTIC, ROUND, CCF-5/8-	119
PPP00000CW12537109	NUT,INSERT,THIN-NUT,LARGE FLANGE	120
PPP00000CW31756101	LABEL, PRECOR USA ICARIAN LINE	121
PPP00000CWAC1009101	PULLEY, 4 1/2 DIA X 1/2 ID	122
PPP00000CWAC218901	HANDLE END CAP W/SET SCREWS, DIA 1"	123
PPP00000CWAC4003101	ACCESSORY, PRO STYLE BAR, SOLID, 32	125
PPP00000CWAC4011101	ACCESSORY, HANDLE , NYLON ROPE W/BA	126
PPP00000CWAC4013101	ACCESSORY, LAT BAR , SOLID, 48"	127
PPP00000CWSA1081731	ASSY,LAT BAR,BLK ZNC	128
PPP00000CWTAYN050100	SCREW, BUTTON HEAD, BLK XYLAN, 1/2	130
PPP00000CWHCYN050275	SCREW, HEX HEAD, BLK XYLAN, 1/2-13	131
PPP00000CWTAYN031100	SCREW, BUTTON HEAD, BLK XYLAN, 5/16	133
PPP00000CWTAYN050200	SCREW, BUTTON HEAD, BLK XYLAN, 1/2	134
PPP00000CWWBKN031007	WASHER, FLAT, TYPE A, SAE, 5/16 ID	135
PPP00000CWWBKN031007	WASHER, FLAT, TYPE A, SAE, 5/16 ID	138
PPP00000CW12537109	NUT,INSERT,THIN-NUT,LARGE FLANGE	139
PPP00000CWHCYN050350	SCREW, HEX HEAD, BLK XYLAN, 1/2-13	145
PPP00000CW31877212	WELDMENT, CONNECTION, 13.75, W/2 PU	150.01
PPP00000CW31877302	WELDMENT, CONNECTION, 13.75, W/2 PU	150.02
PPP00000CW31877322	WELDMENT, CONNECTION, 13.75, W/2 PU	150.03
PPP00000CWCLRA319250	ASSY, CABLE, MARINE EYES, FTS,407B	173
PPP00000CW12589741	CARBINE, HOOK, MEDIUM, 5/16" DIA, 3	174
PPP00000CW30010102	LABEL,WARNING STRENGTH	188
PPP00000CW30011102	LABEL,WARNING WEIGHT STACK	189
PPP00000CWPD1141J101	PAD,4X19,2HOLES,W/BP,BLACK, W/SLIP	191.01
PPP00000CWPD1141J102	PAD,4X19,2HOLES,W/BP,RYL BL, W/SLIP	191.02
PPP00000CWPD1141J114	PAD,4X19,2HOLES,W/BP,CUSTOM,W/SLIP	191.14
PPP00000CW12589742	CARBINE, HOOK, LARGE, 3/8" DIA, 3 1	199
PPP00000CWAC1133101	BUSHING, WEIGHT PLATE, LDPE PLASTIC	203
PPP00000CW10519721	PLATE, WEIGHT, 20 LBS, WRKL BLK	279
PPP00000CW10510721	ASSY, PLATE, WEIGHT, 10 LBS, WRKL B	300
PPP00000CW10520721	ASSY, PLATE, WEIGHT, 20 LBS, WRKL B	301
PPP00000CW30132712	SELECTOR STEM, 20 PLATE,0.875 DIA,	304

PPP00000CW30184902	ASSY,BARREL, TOP PLATE,ALUMINUM	305
PPP0000CWL DNN038200	SLOTTED PIN SPRING, DIA 3/8 X 2	306
PPP00000CW12402101	BUMPER, ID 1.050, BLK RUBBER	307
PPP00000CW12404101	CAP, GUIDE ROD,DIA 3/4, BLK	308
PPP00000CW33870102	ASSEMBLY, 5" WEIGHT STACK PIN & LEA	310
PPP00000CW32937101	WEIGHT STACK LABELS, 10-250, STAGGE	314
PPP00000CW33323721	STACK RISER, 5 INCH, WRINKLE BLACK	315
PPP00000CW32663741	WELDMENT, BOLT ON TOP PLATE MINI ST	316
PPP00000CW32938101	WEIGHT STACK LABELS, 10-300, STAGGE	318
PPP00000CWPF1016101	UHMWPE, GUIDE ROD CAPTURE PLATE	319
PPP00000CWPF1218712	GUIDE ROD,DIA 3/4, #8,CHM	320
PPP00000CWTAYN031175	SCREW, BUTTON HEAD, BLK XYLAN, 5/16	321
PPP00000CWTAYN038125	SCREW, BUTTON HEAD, BLK XYLAN, 3/8	322
PPP00000CWWALYN031008	WASHER, SPLIT, 5/16 ID, BL	323
PPP00000CWWBKN031007	WASHER, FLAT, TYPE A, SAE, 5/16 ID	324
PPP00000CWWCKN075015	WASHER, FLAT, TYPE A, WIDE, 3/4 ID	325
PPP00000CW32651721	WELDMENT, 4.50" TOP PLATE PULLEY HO	326
PPP00000CWAC1009101	PULLEY, 4 1/2 DIA X 1/2 ID	329
PPP00000CWKAYN050031	LOCKNUT, NYLON INSERT, HALF, UNC, 1	331
PPP00000CWTAYN050175	SCREW, BUTTON HEAD, BLK XYLAN, 1/2	332
PPP00000CWWBKN050010	WASHER, FLAT, TYPE A, SAE, 1/2 ID X	333
PPP00000CWAC1177101	FLOOR PROTECTOR, RUBBER, 4.563 X 4.	501
PPP00000CWAC1178101	FLOOR PROTECTOR, RUBBER, 2.563 X 6.	502
PPP00000CWAC1179101	FLOOR PROTECTOR, RUBBER, 4.813 X 2.	503
PPP00000CWAC1180101	FLOOR PROTECTOR, RUBBER, 2.563 X 4.	504
PPP00000CW58004101	WEIGHT STACK BUSHING KIT, KS SERIES	600